

Increasing your efficiency



Variability
Transport direction and line height can be set



Colour touchscreen
5.7" display for easy operation

Benefit from the flexibility of the XE3

The XE3 covers a weighing range of up to 6 000 g – with highest accuracy. Comprising a facility for height adjustment and reversible transport direction, it combines economy and latest weighing technology in a compact system with operator-friendly screen menus and prompts.

Belt speed is continuously variable with constant maximum torque. The conveyor belt can be quickly removed for effective cleaning.

Technical data

XE3

– increasing efficiency with the XE3

XE3 checkweighers offer state-of-the-art, dynamic weighing technology at an economical cost. The standard design of the checkweigher model XE3 comprises a facility for height adjustment as well as reversible transport direction and variable speed control.

The GARVENS XE3 allows for upgrading, adding a wide range of options to the many standard features allowing the checkweigher to be tailored to closely meet the users' requirements.

Its modular concept makes the XE3 service-friendly requiring little maintenance.

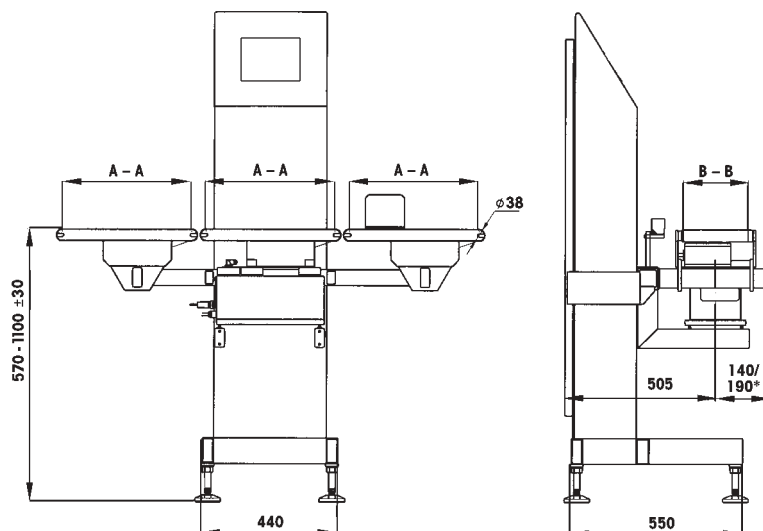

Schematic XE3 – typical dimensions in mm
(A-A, B-B vary depending on conveyor size)

* depending on the width of the conveyor used

Characteristics

- weight classification in 3 weight zones
- flexible integration in production lines
- "Weights and Measures" design-approval in certain countries
- 115 / 230 V AC, 50/60 Hz, single phase, ≥ 500 VA

Weighing terminal

- 100 product memories
- simple operation, various languages
- bright, high-contrast colour touchscreen display, 5.7" (QVGA)
- comprehensive display of current weight data and production screens as well as configuration screens
- Windows-based control, XP embedded

Options and accessories

- feedback control (1 controller) for optimising fill processes
- E. C. approved statistics programs
- PrintStick or printer for the data output
- network interface for FreeWeigh SQC system
- various monitoring facilities (e. g. detection of product backup)
- choice of interfaces for weight transmission
- remote display GARVENS FAZ W100
- range of reject devices
- water ingress protection IP65
- further special options and accessories

* depending on the design and dimensions of the weighing belt used

** within the approved tolerances, depending on the weight, dimensions and transport behaviour of the product to be weighed

Technical details

Technical details	XE3
Weighing range, specific to article weight*	in the range 0 to 6 000 g
Accuracy**	from ± 200 mg
Throughput (weighings/minute)**	max. 200
Roller centres, weighing conveyor (A-A)	250, 300, 400, 500, 600 mm
Belt width, weighing conveyor (B-B)	150, 200, 250, 300 mm
Roller centres, infeed/outfeed conveyor (A-A)	250, 300, 400, 500, 600 mm
Belt width, infeed/outfeed conveyor (B-B)	150, 200, 250, 300 mm
Standard sorting/rejecting device	pusher

nefton
Ζύγιση
Σήμανση
Συμμόρφωση

Νεφτών Τεχνολογίες ABEE

Γέρακα 113, Τ.Θ. 67934

15344 Γέρακας

Τηλ: 210 6654544

Fax: 210 6654545

marketing@nefton.gr

www.nefton.gr

www.mt.com/garvens

For more information