

ROBUST & RELIABLE ■ ■ ■

Robust design with no wear parts requiring zero preventive maintenance

EXTENDED WARRANTIES

Best in industry 18 month standard warranty, 60 months available

DURABLE PRINTHEAD

Unrivalled 12 month printhead warranty

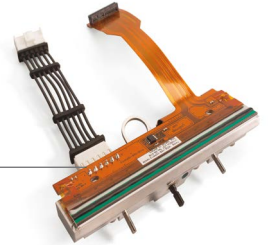

SMART & EFFICIENT ■ ■ ■

Consistent high quality printing of full nutritional labels, ingredient or multi-pack applications

WIDE PRINT AREA

128 mm x 150 mm maximum to print large messages



MULTI-CODE CAPABILITY

Designed to print multiple codes on multi-lane packaging lines

DEAD DOT DETECTION

Enables detection of damaged resistors which impact print quality

IMAGE ADJUSTMENT

Allows the image to be adjusted on the user interface without the need of a laptop

SIMPLE & VERSATILE ■ ■ ■

Suitable for a wide variety of applications

LONGER RIBBON LENGTH

900 meter ribbon in select grades for fewer changeovers and improved uptime

EASY TO USE

Intuitive touch screen with USB connectivity for fast code and ingredient changes



LINE SPEED/RESOLUTION

- ▶ Print speed: Up to 700 mm/s
- ▶ Print area: – Intermittent: 128 mm x 75 mm
Continuous: 128 mm x 150 mm

PRINT FEATURES

- ▶ Automatic printhead setup
- ▶ Dead-dot detection and image adjustment
- ▶ Combined intermittent and continuous printer
- ▶ Easily changes from left to right hand with no additional parts
- ▶ Average gap between prints 0.5 mm
- ▶ Automatic shift codes and serial numbers
- ▶ Multiple variable user input fields with alpha-numeric texts
- ▶ Ribbon saving modes: radial ribbon save, digital ribbon save, interlaced, multi-print triggers and negative ribbon advance
- ▶ Print specifications: full true type font support, including non-Roman characters and symbols. Printing of real-time clock, dates and auto updating best before dates.
- ▶ Barcodes: ITF, Code 39, Code 128, EAN 128, EAN 8, EAN 13, UPC A, UPC E, RSS linear, PDF 417, ID Matrix, QR and Composite RSS barcodes supported

SOFTWARE

- ▶ Included free of charge, CoLOS® Create 5.3 for design of simple messages: also compatible with CoLOS® Create Professional and CoLOS® Enterprise

OPTIONS/ACCESSORIES

- ▶ Web UI for OEM integration
- ▶ Mounting bracket, Encoders

OPERATIONS

- ▶ User interface: Color LCD touch screen for message selection, message adjustment, variable data entry, diagnostic and system setup
- ▶ Monochromatic user interface also available
- ▶ WYSIWYG print preview of printed message, real-time display of remaining print capacity expressed in hours and number of prints
- ▶ Full diagnostics including printhead statistics
- ▶ Robust LED status indicators on the printer
- ▶ Webbing diagram for fast ribbon changes
- ▶ Hardware interface: Inputs: "Print go" and 1 configurable input, Outputs: Fault, warning and 2 configurable outputs
- ▶ S/W interface: USB for downloading images, settings and data files, RS232, Ethernet communications standard, Communications protocols for PC's, PLC and packaging machines, including full remote control web server

OTHER CHARACTERISTICS

- ▶ Supplies: Thermal transfer ribbon available in a variety of grades and colors
- ▶ Maximum ribbon length: up to 900 m, Minimum ribbon width: 55 mm, Maximum ribbon width 130 mm
- ▶ Weight: Printer: 10.2kg, Colour controller: 4.8kg, Mono controller: 4.0 kg
- ▶ Electrical power supply: 90 – 264 V with automatic switching: frequency 47/63 Hz; power 150 VA
- ▶ Air consumption: typically 0.47 ml/print
- ▶ Operating temperature range: 0 to 40° C
- ▶ Humidity: 10% to 90% non-condensing

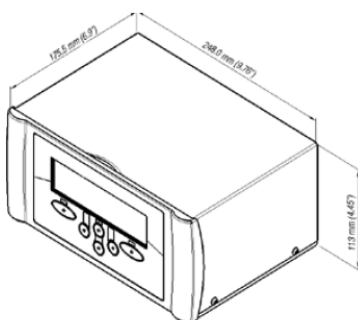

Monochrome Controller

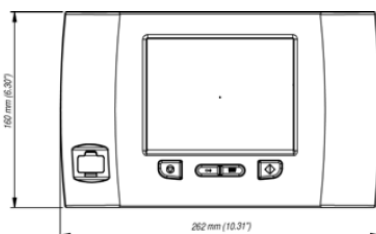

Colour Controller

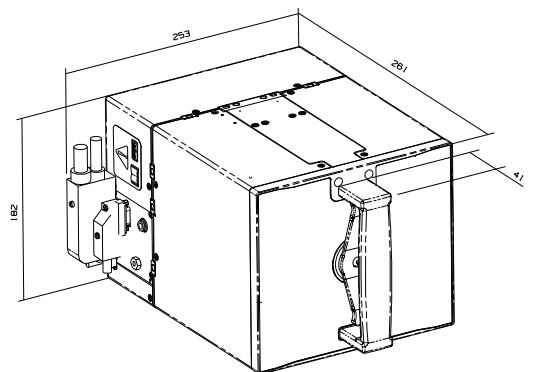

We reserve the right to amend the design and/or specifications of our products without notice.

Markem-Imaje
Global Sales & Marketing Division
9, rue Gaspard Monge
B.P. 110
26501 Bourg-lès-Valence Cedex – France
Tél. : +33 (0) 4 75 75 55 00
Fax : +33 (0) 4 75 82 98 10

markem·imaje
A DOVER COMPANY



To learn more, visit www.markem-imaje.com