

5200 / 5400

large character hot melt inkjet case printers ■ ■ ■



Our technology ■ ■ ■

Precise and dependable - Our 5200 and 5400 high resolution, large character inkjet printers combined with our Touch Dry® Hot Melt inks deliver superior print quality and consistency on corrugate cases, trays and wrapping films.

Touch Dry® Hot Melt inks print images which dry instantly on contact with no bleeding or fading; producing 100% readable barcodes. Touch Dry® inks are solvent free, environmentally safe, and employee friendly in formulation and handling.

Your benefits ■ ■ ■

Productivity – The correct information on every case, every time. Touch Dry® Hot Melt ink eliminates the need for multiple ink formulations and change-over. Stage or add ink without stopping the production line. Our solvent-less ink and auto-purge technology reduce operator maintenance.

Performance – Touch Dry® Hot Melt inks print on a wide range of substrates and environmental conditions. Large drop volume at high frequency provides reliable printing at speeds up to 178 m/min. Multiple dye and pigment based inks and customizable printer settings give total image control.

Flexibility – Multiple jetting orientations; single side, opposite side, side and front, and top printing. Product configuration options include scanners, encoders, printhead slide assemblies, and stands. The 5200 or 5400 can be integrated with production lines, databases, or ERP systems via CoLOS® Enterprise software.



markem·imaje

the team to trust ■ ■ ■

Print features ■ ■ ■

- Print Head (PH) dpi
Vertical dpi: 200
Addressable Jets: 256
Nozzles: 512
- Print speed: Continuous
Print density 1 - 200 by 150 dpi
Up to 178 m/min
Print density 2 - 200 by 300 dpi
Up to 89 m/min
Print density 3 - 200 by 450 dpi
Up to 59 m/min
Print density 4 - 200 by 600 dpi
Up to 44 m/min
Print density 5 - 200 by 750 dpi
Up to 36 m/min
- Print densities available: 1 to 10
- Encoder scaling: Allows for conveyor line speed matching and for higher print speeds with a reduction in the print resolution
- Slant mode: Increases PH vertical dpi from 200 to 282 with a maximum image height of 46 mm
- Print area: Maximum/PH print height: 65 mm
Print length: 1,200 mm
- Print specification Extended ASCII character set
- Printing of real time clock (hr/min/sec), dates and auto updating best before dates and serial numbers
- Barcodes (Linear): ITF, Code 39, Code 128, EAN 128, EAN 8, EAN 13, UPC A, UPC and RSS
- Barcodes (2D): Static Datamatrix, Composite RSS and dynamic QR

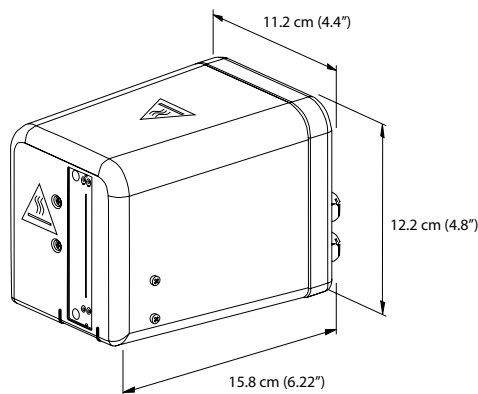

To learn more, visit www.markem-imaje.com



We reserve the right to amend the design and/or specifications of our products without notice.

Operations ■ ■ ■

- 5200: Up to two PH's
5400: Up to four PH's
- User interface: Backlit graphics display keypad utilized for image selection, variable data entry, diagnostics and system setup.
- Selectable multi-language menus
- Image preview
- Access level password protection
- Three level of user messages: Information, Warnings and Errors
- Full system diagnostic menu
- PH orientations: Vertical, horizontal and down jetting
- PH daily care: Purging and Test print capability
- Recommended software: CoLOS® image creation, database and networking software
- Encoder options: Internal: For fixed conveyor speed printing
External: For optimizing print quality and recommended for bar code printing
- Photo-Edge sensors: Print (trigger) signal and a maximum of two/system
- Communications protocols: Ethernet, RS232 and RS485
- Hardware outputs: Fault relay (Dry contact)
- Ink replenishment: User prompted when to add ink and can be added w/o interfering with the operation of the printer
- Interfaces: Hand held wedge product select scanner. Remote keyboard.

Other characteristics ■ ■ ■

- Weight: PH: 1.8 kg
5200 control box: 64 kg
5400 control box: 77 kg
- Hot melt inks: Available in various series, colors, bottles and ink blocks
- PH wipes: Support daily PH care requirements
- Electrical and environmental: 5200: 115/200/208/230V, 50-60Hz - 1,450 watts maximum. 5400: 200/208/230V, 50-60Hz - 2,530 watts maximum. CE Marked. ETL listed, conforms to ANSI/UL 60950, 3rd edition (2000); CAN/CSA No. 60950-00, 3rd edition (2000).
- Operating environment of 0° to 40° C (32° to 104° F). IP45 protection (cabinet only w/door closed). IP42 protection (print head)
- Air: System generated
- Signal tower (beacon) assembly
- Manuals: Operator manual in local language with installation, setup and service guide in English only

Options ■ ■ ■

- PH Slide Assembly
- Stainless steel cabinet
- Post print bar code scanner assembly
- TU Look-up assembly
- Printer service kits
- Preventive maintenance kits & contracts
- Regional telephone technical & product support
- Web site technical & product support

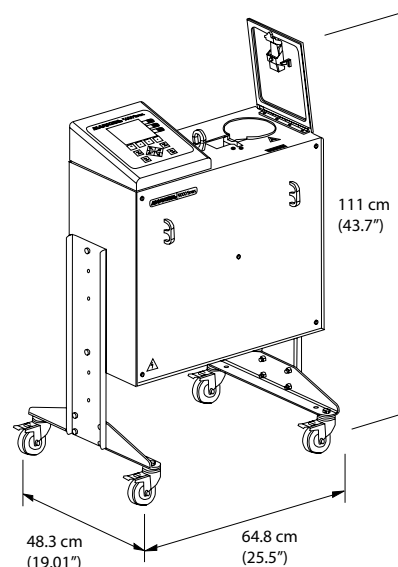

9, rue Gaspard Monge
B.P. 110
26501 Bourg-lès-Valence Cedex - France
Tel.: +33 (0) 4 75 75 55 00
Fax: +33 (0) 4 75 82 98 10

150 Congress Street
Keene, NH 03431
United States of America
Tel.: +1 800-258-5356
Fax: +1 603-357-1835



markem·imaje

A DOVER Company