

Weighing terminals



The stainless steel weighing terminals of the 4 Series: **IND429, IND439 and IND449**

The optimal solution for demanding applications in the food, pharmaceutical and chemical industries.

IP69K
GMP
EHEDG
NSF

Precision in stainless steel
Easy to clean – perfect hygiene

METTLER TOLEDO



Pharmaceutical industry

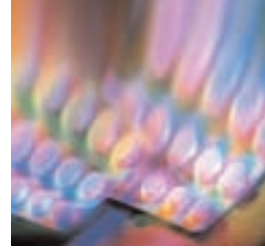

4 Series weighing terminals for reliable processes and precise results:

- GMP-compliant design
- MinWeigh warning function for defined minimum weight
- Connectable precision scale
- Clearly identifiable scale
- 2-scale system for formula weighing
- Battery-operated mobility



Chemical industry



Rugged solutions for the demanding environments of the chemical industry:

- Version for hazardous areas
Zone 2 and 22
- IP69K, dust- and water-tight
- Stainless steel housing for aggressive environments
- Good readability through backlighting
- Easy process integration through a variety of data interfaces (RS232, Ethernet, etc.)
- WLAN interface for wireless communication



Food industry

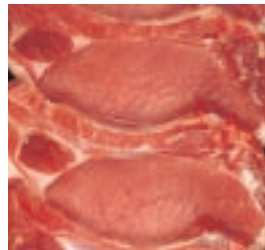

Optimal solution for hygienically sensitive areas:

- IND4x9 terminal and PBA430 weighing platforms—the ideal combination for NSF, EHEDG and IP69K requirements
- NSF- and EHEDG-compliant:
 - NSF: National Sanitation Foundation
 - EHEDG: European Hygienic Engineering and Design Group
- IP69K, allows high-pressure cleaning
- Easy cleaning through optimized design
- Extremely hygienic surfaces
- Versions for \pm weighing available

(see data sheet no. 22014096)

Functions

Ergonomically designed display and keypad



EHEDG

Hygiene

The IND4x9 was specially designed for use in hygienically sensitive areas. Its smooth surface and the materials used in its construction allow it to be cleaned easily and completely. NSF and EHEDG have made a positive appraisal of the devices. The certificates and reports can be viewed at www.mt.com



Water ingress protection

Protected to IP69K in accordance with DIN 40050, the weighing terminals are suitable for use in harsh environmental conditions. The devices are dust-tight and can be cleaned with high-pressure equipment.

GMP

Good Manufacturing Practice

The terminals were evaluated as "Very well suited to GMP-compliant work!" by the Steinbeis Transfer Institute at the University of Berlin, due to its cleanability, calibration, surfaces and qualification documentation.

Mobility

The weighing terminal can also be supplied with an optional battery. The battery is built-in, which provides optimal protection against damage and loss. A charge indicator informs you when the battery needs to be charged. The battery allows you to work between 9 and 90 hours off the line.
 9h: continuous operation
 90h: 10% operating time, Power-off mode switched on
 (Typical values for a scale with 4 DMS weighing cells and without auxiliary interface)

Display

Backlit, 7-digit, 7-segment LC display IND439 and IND449:
 Auxiliary display for piece counting, and graphic display of the weighing capacity and \pm display for checkweighing.

Explosion Protection

IND4x9 terminals are available in a version designed for hazardous areas. As non-sparking equipment, they meet the requirements of Category 3 and can therefore be used in Zones 2 (gas) and 22 (dust). A complete range of weighing platforms is available for hazardous areas.



Interfaces

A range of interfaces options are available (see options) for connection to computers and printers. The interfaces are installed in a protected position at the back of the terminal and are accessible via IP69K-protected sockets.

Wireless LAN

Communication without a cable! IND4x9 terminals with an IEEE 802.11b WLAN interface, which allows easy integration of the instruments into a WLAN network, are available as options. WEP and WPA coding ensures data security. The WLAN module can be easily configured using a WEB browser.

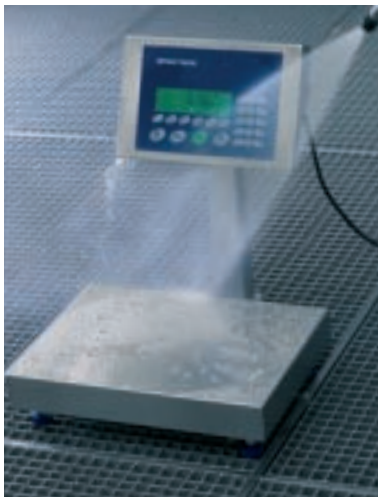

Solutions



PBA430 weighing platforms

The ideal addition for applications in harsh industrial environments. The weighing platforms of the PBA430 line are protected to IP69K, approved by EHEDG and NSF, and manufactured entirely of stainless steel.

Weighing capacity: 3 kg to 600 kg

Platform size: 240 x 300 to 600 x 800 mm



Weighing platforms

All weighing platforms from METTLER TOLEDO can be connected to the IND4x9 terminal.

Whether the IDNet interface is analogue or digital, an optimal solution can be assembled from our broad product range.

The picture shows a PUA4579 low-profile scale made of stainless steel.



4 Series family

The IND4x9 weighing terminals are a stainless steel addition to the 4 Series. The 4 Series family comprises various types of construction with identical functions:

BBA4xx: Compact scale with analog weighing sensor

BBK4xx: Compact scale with force compensation sensor

IND4x5: Weighing terminal, IP65, aluminum housing

The picture shows an example of a compact scale



Accessories: GA46 printer

The GA46 thermal printer is available for connection via RS232 interface to an IND4x9 terminal. Stainless steel housing.

An IP65-protected version with cover and take-up device is also available.

Specifications



| Functions | IND429 | IND439 | IND449 |
|---|--------|--------|--------|
| Zeroing | • | • | • |
| Taring | • | • | • |
| Dynamic weighing | • | • | • |
| Unit switching | • | • | • |
| Printing/data transfer | • | • | • |
| MinWeigh | • | • | • |
| Display gross weight, tare, high resolution | – | • | • |
| 2-scale operation | – | • | • |
| Displays capacity utilisation | – | • | • |
| Counting | – | • | • |
| Checkweighing | – | – | • |
| Memory space for tare, target values, unit weights and tolerances | – | – | • |
| Totaling/subtracting | – | – | • |
| IDs (2 values) | – | – | • |
| Date/time | – | – | • |
| Number of keys | 6 | 10 | 25 |
| Scale connections (max.) | 1 | 2 | 2 |
| Battery operation | • | • | • |
| IP69K protection | • | • | • |

Options

Interfaces

The terminals are as standard equipped with an RS232 interface and a scale connection. The scale connection can be supplied with analogue or digital (IDNet) weighing platforms. The following options are also available:

- Second RS232 interface
- RS422/RS485 interface
- Ethernet interface
- Wireless LAN interface
- USB (slave) interface
- Digital I/O (4 inputs and 4 outputs)
- For an analogue IND439/IND449: a second analogue scale connection
- For a digital IND439/IND449: a second digital IDNet scale connection

Additional Options

- Terminal with internal battery (integrated charging circuit included)

Options that must not be used in hazardous areas:

- Terminal for external power requirements 12 to 24VDC (5 m connection cable with connector included)

Note:

- You can find additional technical data in the IND4x9 Data Sheet
- All terminals are available in a Category 3 version for hazardous areas

Dimensions

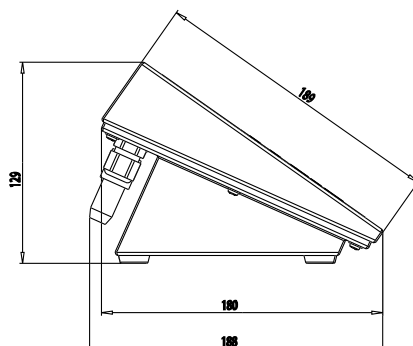
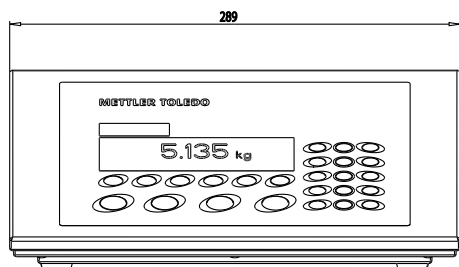

Accessories

| | Order No |
|---|-------------|
| GA46 thermal printer, stainless steel housing, RS232 interface, 2.5m cable included | 00505471 *1 |
| GA46 thermal printer, stainless steel housing, RS232 interface, 0.4m cable included | 00507229 *1 |
| GA46-W thermal printer, stainless steel housing, RS232 interface, IP65, protective cover, take-up device, 2.5m cable included | 00505799 *1 |
| GA46-W thermal printer, stainless steel housing, RS232 interface, IP65, protective cover, take-up device, 0.4m cable included | 00507230 *1 |
| AD1419 auxiliary display (IP69K, RS232, 3 m cable included, display without backlighting) | 22013962 *1 |
| AD1419-B auxiliary display (IP69K, RS232, 3 m cable included, display with backlighting) | 22014022 *1 |
| RS232 cable SICS auxiliary balance (3 m, 8-pin <-> 9-pin Sub D connector) | 22006795 *2 |
| RS232 cable for PC (3 m, 8-pin <-> 9-pin Sub D socket) | 00504376 *2 |
| RS232 adapter, 8-pin | 00503756 *2 |
| RS422/RS485 cable (3 m, 6-pin <-> open ends) | 00204933 *2 |
| RS485 adapter, 6-pin | 00204866 *2 |
| Ethernet 10/100 Base T twisted pair cable (5 m -> 8-pin RJ45) | 00205247 *2 |
| Ethernet 10/100 Base T twisted pair Kabel (20 m -> 8-pin RJ45) | 00208152 *2 |
| USB adapter cable (0.2 m -> USB series A socket) | 22006268 *2 |
| USB adapter cable (3 m -> USB series A socket) | 22007713 *2 |
| Relay box for digital I/O option | 22011967 *1 |
| Cable between digital I/O option and relay box (10 m) | 00504458 *2 |
| Digital I/O adapter, 19-pin | 00504461 *2 |
| Protective cover for terminals IND4x9 (3-piece set) | 22013963 *1 |
| Stand, stainless steel, for IND4x9 and PBA430, height 330 mm | 22013964 - |
| Stand, stainless steel, for IND4x9 and PBA430, height 660 mm | 22013965 - |
| Stand, stainless steel, for IND4x9 and KA, KB, MA, MB and DB weighing platforms | 22014836 - |
| Bench stand, stainless steel, for IND4x9, suitable for bench stand 00503632 and 00504854 | 22014835 - |
| Floor stand, stainless steel, for IND4x9 | 22014834 - |
| Stand base for floor stand | 22011982 - |
| Wall adapter, stainless steel, for IND4x9, tiltable | 22013966 - |
| Wall bracket, stainless steel, for IND4x9, tiltable and rotatable | 22014833 - |
| GA46 mounting adapter, stainless steel, for bench and floor stands and wall bracket | 22011985 *1 |

The following comments apply only to hazardous area installations:

*1 These instruments/accessories must not be used in hazardous areas!

*2 These accessories can be used to connect a terminal in a hazardous area with an instrument in a nonhazardous area

Sales and service:



Νέων Τεχνολογιών ΑΒΕΕ
Γέρακα 113,Τ.Θ. 67934
15344 Γέρακας
Τηλ: 210 6654544
Fax: 210 6654545
marketing@nefton.gr
www.nefton.gr

www.mt.com

For more information

ServiceXXL
Tailored Services



Service XXL

- Integral service plan
- Custom-designed service packets
- Service contracts
- On-site calibration certificates
- Minimum weight determination with MinWeigh

Quality certificate.

Development, production and testing to ISO 9001. Environmental management system to ISO 14001.

«Conformité Européenne».

This mark means you can rest assured that our products meet the requirements of the latest EU guidelines.