

## Guide for installers

# METTLER TOLEDO MultiRange Explosion-protected weighing system with the ID7sx weighing terminal

METTLER TOLEDO

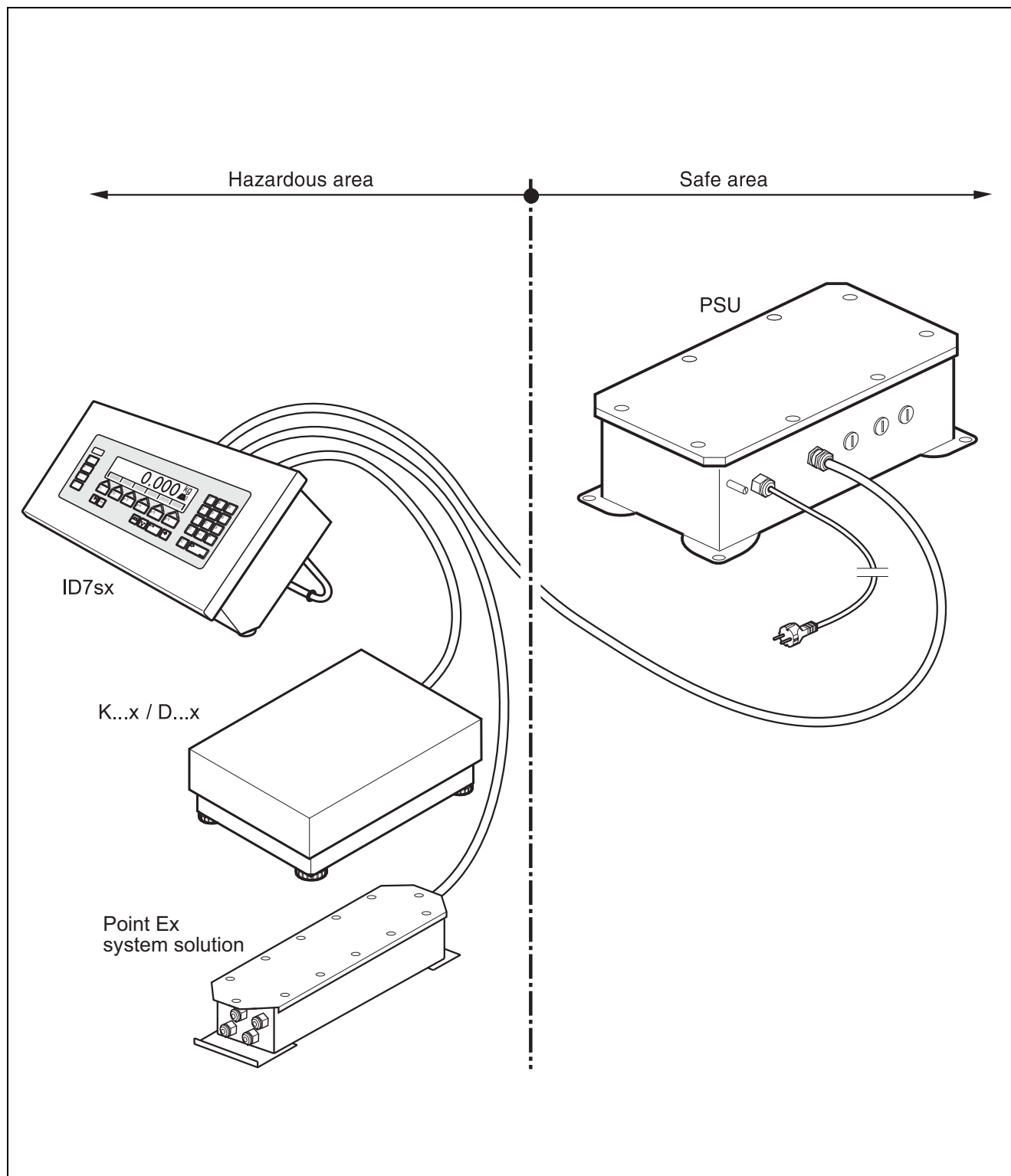



<b>Contents</b>		Page
<b>1</b>	<b>Safety instructions</b> .....	<b>2</b>
<b>2</b>	<b>System overview</b> .....	<b>3</b>
2.1	Typical configurations .....	3
2.2	Description of the components .....	6
<b>3</b>	<b>Installation</b> .....	<b>7</b>
3.1	Setting up system modules .....	7
3.2	Connecting devices .....	10
3.3	Selecting peripheral devices .....	11
3.4	Equipotential bonding .....	12
3.5	Connecting power supply .....	12
<b>4</b>	<b>Optional work</b> .....	<b>13</b>
4.1	Making connection cables .....	13
4.2	Installing additional scale interface or active CL/IDNet module.....	14
4.3	Installing memory module .....	16
4.4	Installing additional data interface.....	17
4.5	Installing digital inputs/outputs .....	18
4.6	Connecting barcode scanner .....	19
4.7	Attaching Profibus-DP module.....	20
<b>5</b>	<b>Dimensional drawings</b> .....	<b>21</b>
5.1	Desk unit .....	21
5.2	Panel unit .....	22
5.3	Wall unit.....	22

# 1 Safety instructions



The ID7sx weighing terminal is approved for operation in zone 1 and 21 hazardous areas. It may only be used in areas in which the causes of static electricity build-up, which lead to propagating brush discharges, have been eliminated.

If the ID7sx weighing terminal is used in hazardous areas, special care must be taken. The code of practice is oriented to the "Safe Distribution" concept drawn up by METTLER TOLEDO.

- Competence** ▲ The weighing system may only be installed, maintained and repaired by authorised METTLER TOLEDO service personnel.
- Ex approval**
- ▲ No modifications may be made to the terminal and no repair work may be performed on the modules. Any weighing platform or system modules that are used must comply with the specifications contained in the installation instructions. Non-compliant equipment jeopardises the intrinsic safety of the system, cancels the Ex approval and renders any warranty or product liability claims null and void.
  - ▲ The safety of the weighing system is only guaranteed when the weighing system is operated, installed and maintained in accordance with the respective instructions.
  - ▲ Also comply with the following:
    - the instructions for the system modules
    - the regulations and standards in the respective country
    - the statutory requirement for electrical equipment installed in hazardous areas in the respective country
    - all instructions related to safety issued by the owner
  - ▲ The explosion-protected weighing system must be checked to ensure compliance with the requirements for safety before being put into service for the first time, following any service work and every 3 years, at least.
- Operation**
- ▲ Prevent the build-up of static electricity. Always wear suitable working clothes when operating or performing service work in a hazardous area.
  - ▲ Do not use protective coverings for the device.
  - ▲ Avoid damage to the system components.
- Installation**
- ▲ Only install or perform maintenance work on the weighing system in the hazardous areas if the following conditions are fulfilled:
    - if the intrinsically safe characteristic values and zone approval of the individual components are in accord with one another,
    - the owner has issued a permit ("spark permit" or "fire permit"),
    - the area has been rendered safe and the owner's safety co-ordinator has confirmed that there is no danger,
    - the necessary tools and any required protective clothing are provided (danger of the build-up of static electricity).
  - ▲ The certification papers (certificates, manufacturer's declarations) must be present.
  - ▲ Lay cabling securely so that it does not move and effectively protect it against damage.
  - ▲ Only route cables into the housing of the system modules via the suitable screw gland and ensure proper seating of the seals.

## 2 System overview

### 2.1 Typical configurations

Two power supply units are available for a weighing system with the ID7sx weighing terminal: PSU and PSUX.

**PSU** Power supply unit in a safe area, multiple-scale connection and connection of peripheral devices are possible

**PSUX** Power supply unit in hazardous area, connection of only one scale possible

#### 2.1.1 Weighing terminal ID7sx, PSU and max. 3 weighing platforms

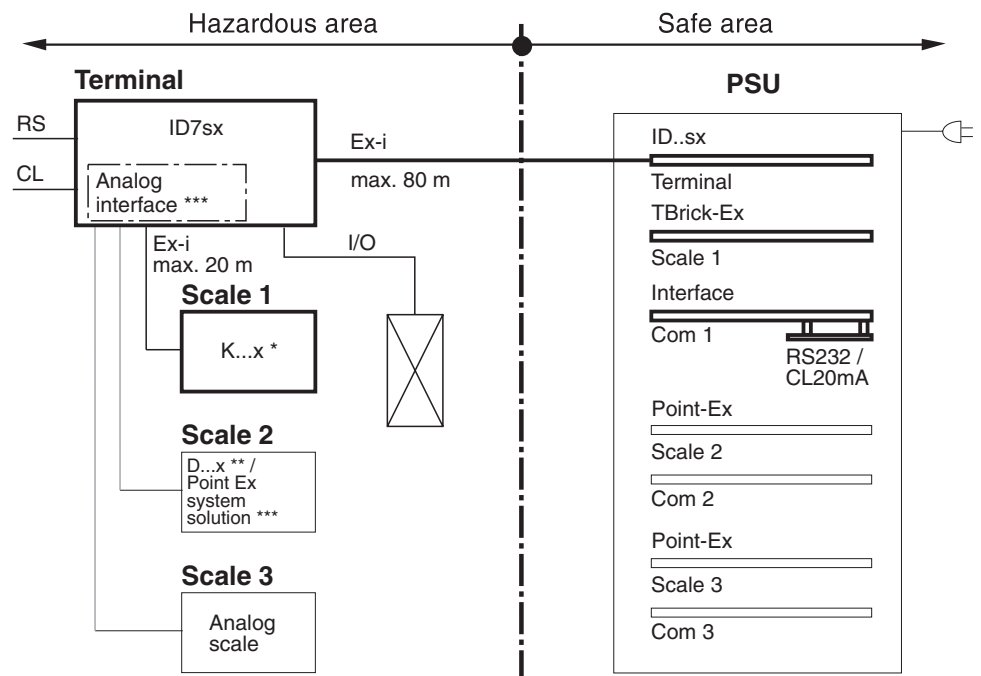

\* Only K...x weighing platforms with a TBrick...-Ex measuring cell are permissible in this configuration.

\*\* D...x weighing platforms with in-built Point Ex A/D converter.

\*\*\* Minimum supply impedance 87  $\Omega$  in conjunction with slotcard Point-Ex.  
Minimum supply impedance 250  $\Omega$  in conjunction with slotcard TBrick-Ex.

### 2.1.2 ID7sx weighing terminal, PSUx and 1 weighing platform

In conjunction with the PSUx power supply unit, only **one weighing platform** (K...x, D...x, analog scale) **or one Point Ex system solution** can be connected to the ID7sx weighing terminal.

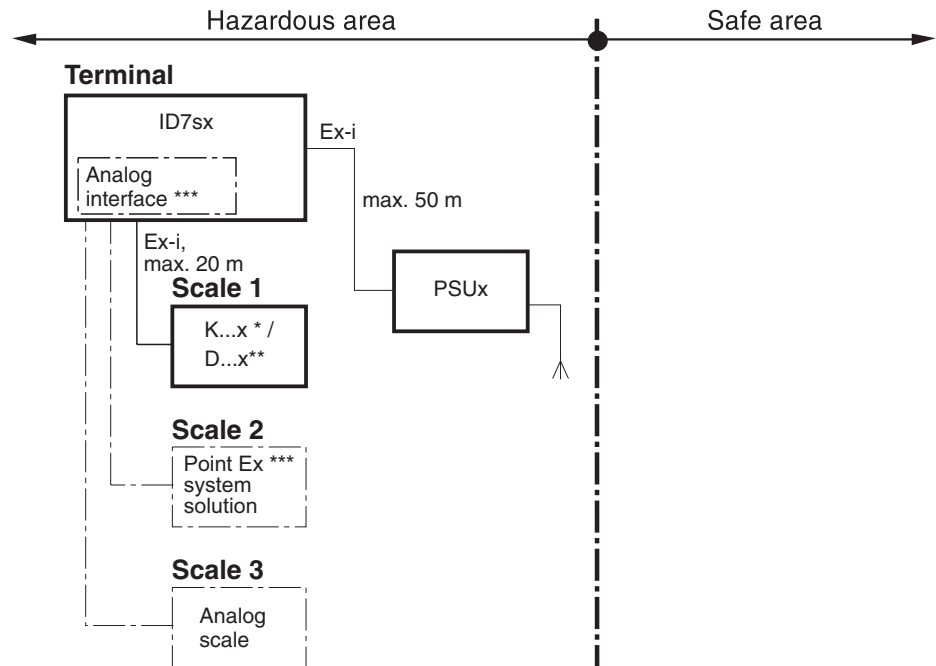

\* Only K...x weighing platforms with a TBrick...-Ex measuring cell are permissible in this configuration.

\*\* D...x weighing platforms with in-built Point Ex A/D converter.

\*\*\* Minimum supply impedance 250 Ω. Here, a maximum of 4 load cells with a cell impedance ≥1000 Ω can be connected.

**2.1.3 ID7sx weighing terminal, PSU, max. 2 weighing platforms and barcode scanner**

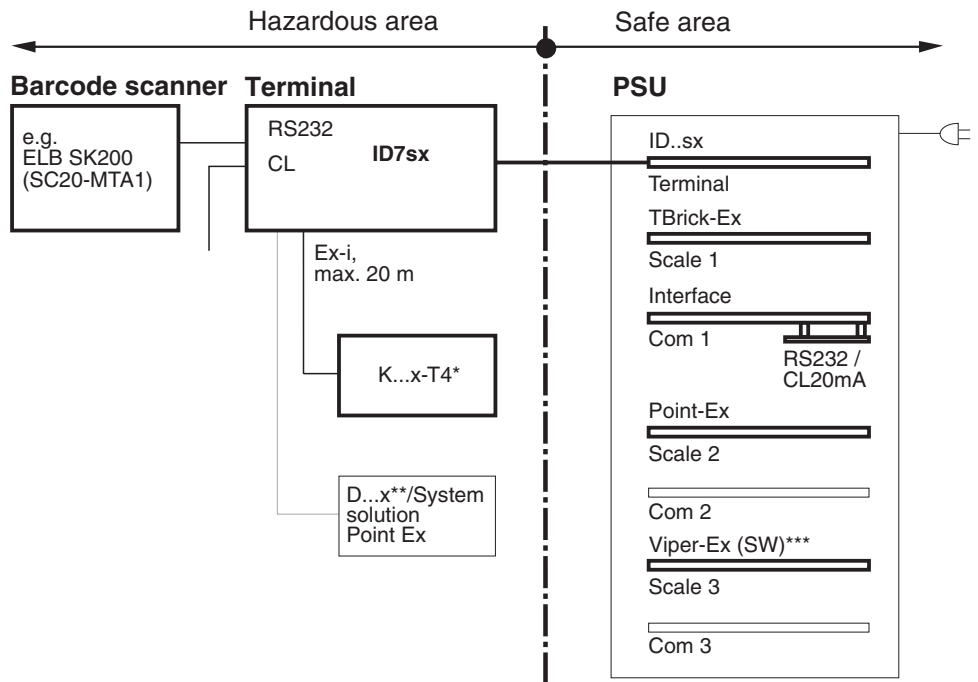

- \* Only K...x weighing platforms with a TBrick...-Ex measuring cell are permissible in this configuration.
- \*\* D...x weighing platforms with in-built Point Ex A/D converter.
- \*\*\* Slotcard Viper-Ex (SW) as a power supply card for barcode scanners.

**2.1.4 D7sx weighing terminal, PSU, connection to Profibus-DP**

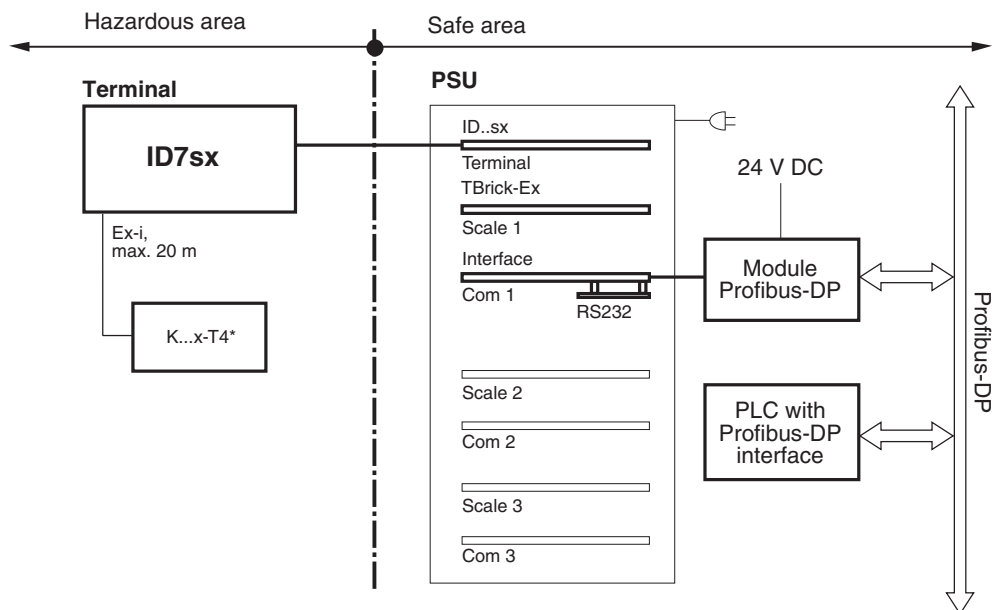

## 2.2 Description of the components

### 2.2.1 Approvals

**ID7sx weighing terminal** Ignition protection type EN II 2G EEx ib IIC T4 -10 °C to +40 °C  
 II 2D IP65 T +55 °C  
 FM Class I, II, III; Division 1; Group A, B, C, D, E, F, G

**Power supply unit PSU/PSUx** See installation instructions for PSU or PSUx

**K...x / D...x weighing platforms** See operating/installation instructions of the K...x or D...x weighing platforms.

**System solution Point Ex** See guide for installers system solution Point Ex.

### 2.2.2 Connections

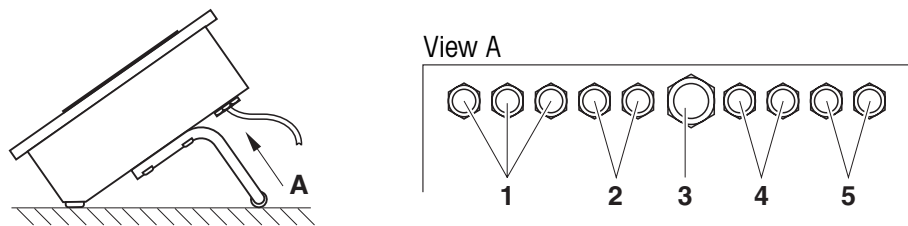

- 1 Weighing platform connections W1, W2, W3
- 2 I/O (outputs) connection / PSUx connection
- 3 PSU connection
- 4 I/O (inputs) connection
- 5 Connection for serial interfaces C2, C3

### 2.2.3 Connection options for ID7sx

Scale interfaces		Scale 1	Scale 2	Scale 3
	IDNet	standard	optional	optional
	Analog interface	–	optional	optional
	Active CL/IDNet interface	–	optional	optional
Serial interfaces		C1	C2	C3
	CL20mA	standard	optional	optional
	RS232	–	optional	optional
Digital inputs/outputs	8 I/O-ID7sx	optional		
Memory module	Memory-ID7sx	optional		



## 3 Installation



### EXPLOSION HAZARD

The explosion-protected weighing system may only be installed according to the respective guide for installers and the accompanying terminal diagram, depending on the power supply unit.

Power supply unit	Guide for installers	Terminal diagram
PSU	ME-22006472	PSU-ID7sx ME-22006478
PSUx/230V	ME-22006386	PSUx/230V-ID7sx ME-22006397
PSUx/120V	ME-22006395	PSUx/120V-ID7sx ME-22006399

### 3.1 Setting up system modules

#### 3.1.1 Setting up ID7sx weighing terminal

→ Select a suitable installation site.

#### Bench stand or floor stand mounting

1. Remove stand clip on the ID7sx.
2. Place weighing terminal onto the bench or floor stand and mount with 4 screws.

#### Wall mounting

The ID7sx weighing terminal can be mounted to a wall using the wall bracket (accessory).

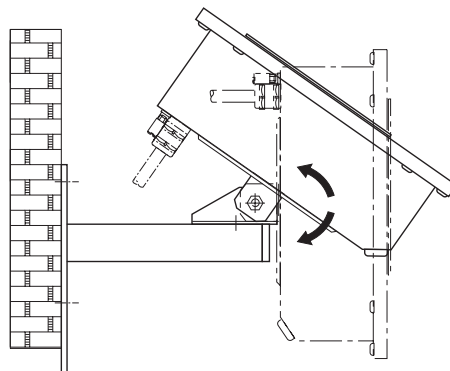

- Procedure**
1. Drill securing holes and fit plugs in accordance with the drilling template on Page 23.
  2. Remove stand clip on the ID7sx.
  3. Mount wall stand to weighing terminal with 4 screws.
  4. Mount wall stand to the wall with the supplied 3 screws.

#### Installation in a switch cabinet

The mounting materials and a drilling template are included in the scope of supply.

→ Discontinue the power supply before beginning installation work.

#### Producing cut-out on switch cabinet

1. Tape the drilling template onto the inside of the switch cabinet and mark the holes with a punch.
2. Drill holes with the specified diameter.
3. Saw out the cut-out for the cover exactly with the sabre saw, as otherwise protection type IP65/IP66 will no longer be ensured.
4. Remove the drilling template from the switch cabinet again.

#### Preparing cover

1. Unscrew all screws on the cover of the ID7sx and remove the cover toward the front.
2. Unplug keyboard and display cables from the IDsx7 PCB.

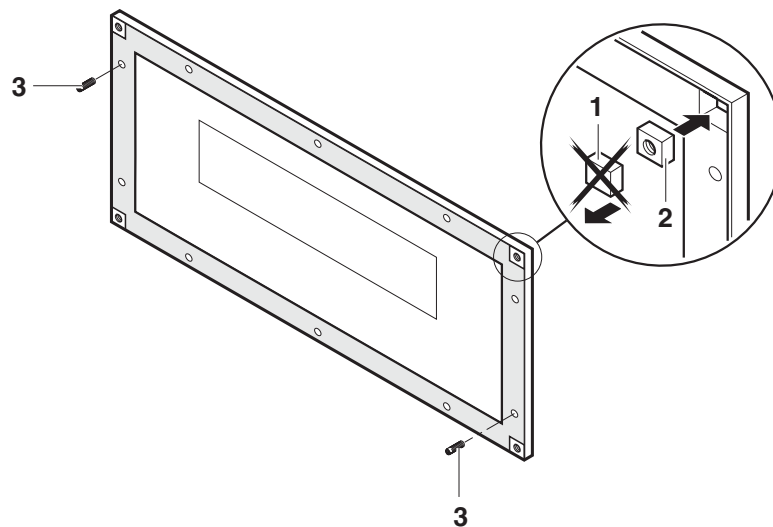

3. Take out the cover seal and cut out the perforated corners of the cover seal (1) with a sharp knife.
4. Insert the square nuts (2) with the rounded side facing downward.
5. Screw the two setscrews (3) into the holes in the cover as shown.

### Mounting cover on switch cabinet

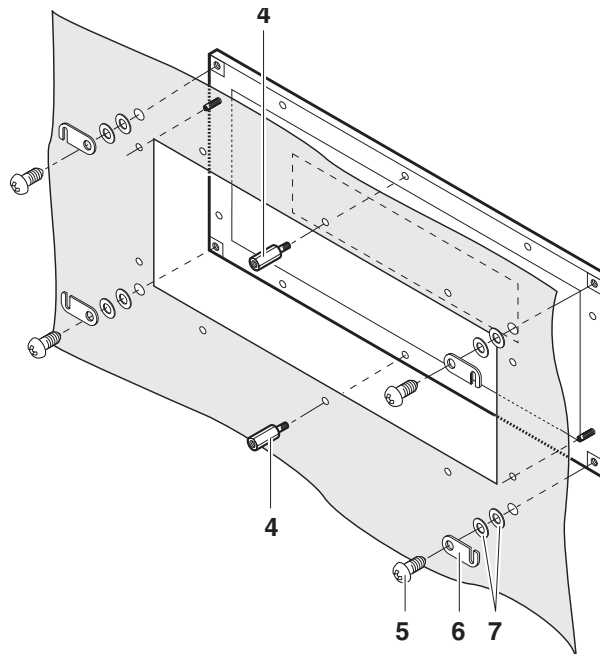

1. Position the cover on the switch cabinet door from the front with the setscrews.
2. Secure the cover with the two centre screws (4) from the inside.
3. Fix the housing claws (6) with the large screws (5) and the washers (7) in all corners. Do not tighten the screws yet!

### Mounting lower housing section

1. Reconnect the display and keyboard cables on the ID7sx PCB.

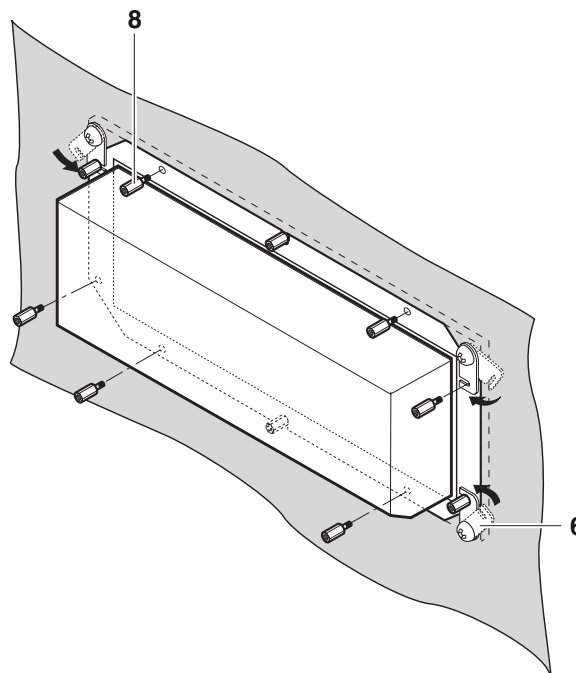

2. Position the lower housing section on the cut-out and secure it with the housing claws (6).
3. Secure the device with 8 screws (8) on the cut-out and tighten all screws.

### 3.1.2 Setting up power supply unit

- Set up the power supply unit in accordance with the respective terminal diagram and the accompanying guide for installers.

### 3.1.3 Setting up weighing platforms

#### Note

When operating using the PSU power supply unit, a corresponding slotcard must be installed for each weighing platform or system solution Point Ex.

- Set up weighing platform or analog scale in accordance with the K...x or D...x operating/installation instructions or guide for installers.

## 3.2 Connecting devices

Connect the devices in the following order:

1. Weighing platform(s) and/or system solution Point Ex to ID7sx weighing terminal.
2. Interfaces (I/O, CL, Active CL/IDNet or RS232) if present.
3. ID7sx weighing terminal to PSU or PSUx power supply unit.
4. Equipotential bonding, see Section 3.4.
5. Connect power supply, see Section 3.5.

### 3.2.1 Preparatory work

Connection of the devices is generally carried out with the accompanying standard cables. Cables of other lengths can be used instead of the standard cables if they are made in accordance with Section 4.1. This applies for the connections

- from the weighing platform or system solution Point Ex to the weighing terminal,
- from the weighing terminal to the power supply unit,
- from the interface(s) to the weighing terminal.

### 3.2.2 General connection procedure

1. Open the device.
2. Insert custom-made cable. To do this
  - remove the blind plug
  - ensure exact course of cable and properly positioned seals
  - tighten screw gland, using a tubular hexagon box spanner if possible
3. Connect cable in the device according to the terminal diagram.
4. Lay cable in the cable holders on the inside of the housing.
5. Attach plug label.
6. Close device.

### 3.2.3 Connection of the digital inputs/outputs at the ID7sx

#### CAUTION

Design, calculation and installation of equipment to the digital inputs/outputs is **solely the responsibility of the owner**.

1. Connect only intrinsically-safe equipment.
2. Check characteristic values for intrinsic safety in accordance with the conformity certificate of the ID7sx and the equipment to be connected according to the conditions in Section 3.3. Document checking of the characteristic values.
3. Make a cable on the weighing terminal side in accordance with Section 4.1 and on the peripheral side according to the device to be connected. Heed the maximum cable length here.
4. Connect the cable on the peripheral device side according to the intended device there. Ensure correct polarity here:

#### Wiring of the inputs

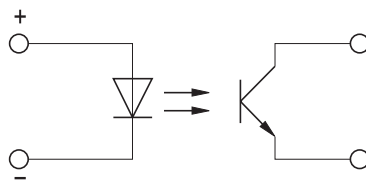

#### Wiring of the outputs

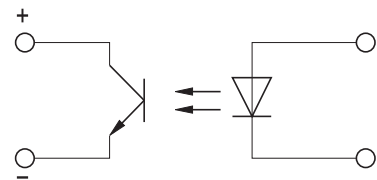

### 3.3 Selecting peripheral devices

#### CAUTION

Refer to the approval documentation of the peripheral device for all characteristic values of the peripheral device listed in the following.

The following conditions must be fulfilled. See also terminal diagram 22006478:

1.  $U_i$  (ID7sx)  $\geq U_o$  (peripheral device)
2.  $I_i$  (ID7sx)  $\geq I_o$  (peripheral device)
3.  $P_i$  (ID7sx)  $\geq P_o$  (peripheral device)
4.  $C_i$  (ID7sx)  $\leq C_o$  (peripheral device)
5.  $L_i$  (ID7sx)  $\leq L_o$  (peripheral device)
6.  $L$  (cable) /  $R$  (cable)  $< L_{a \max}$  (peripheral device) /  $R_a$  (peripheral device), where  $L$  (cable) is the length-based inductivity and  $R$  (cable) is the length-based resistance of the cable to be used.

#### Calculating $L_{a \max}$ / $R_a$ for the peripheral device

Using the ignition protection type-dependent energy value  $e$  of the peripheral device yields the following:

$$L_{a \max} / R_a = 32 / 9 * e * R_i \text{ (peripheral device)} / U_{\max}$$

where  $e = 40$  mJ for equipment of ignition protection type IIC.

### 3.4 Equipotential bonding

Equipotential bonding must be installed by an electrician authorised by the owner. METTLER TOLEDO Service only has a monitoring and consulting function here.

- Connect equipotential bonding (PA) of all devices (power supply unit, weighing terminal and weighing platform) in accordance with the terminal diagram and the country-specific regulations and standards. In the process it must be ensured that
  - all device housings are connected to the same potential via the PA terminals
  - no circulating current flows via the cable shielding for intrinsically-safe circuits
  - the neutral point for equipotential bonding is as close to the scale as possible

### 3.5 Connecting power supply



#### **EXPLOSION HAZARD**

The mains connection of the power supply unit must be made by a professional electrician authorised by the owner and in accordance with the respective terminal diagram and the accompanying installation instructions and the country-specific regulations.

## 4 Optional work

### 4.1 Making connection cables

Customer-specific weighing platform cables for intrinsically-safe circuits must be fabricated as follows:

	Cable	Dimension A (ID7sx)	Dimension B	Max. length
<b>ID7sx – PSU</b>	9x2x0.5 mm <sup>2</sup>	215 mm	215 mm	80 m
<b>ID7sx – weighing platform / system solution Point Ex</b>	3x2x0.75 mm <sup>2</sup>	215 mm	80 mm	20 m

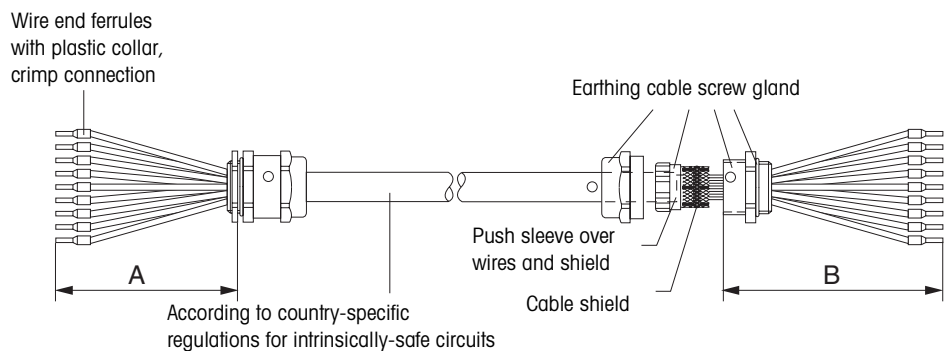

1. Cut cable to length and strip cable ends according to dimension A/B.
2. Shorten shielding on both sides to 10 mm.
3. Strip wire ends.
4. Crimp wire end ferrules onto wire ends with a crimping tool.
5. Push second rear section of earthing cable gland onto cable.
6. Push sleeve over wires and shield. Fold over cable shield.
7. Push on front section of cable gland and screw onto rear section.

#### Observe the following when connecting the weighing platform

1. When opening the terminal box of the weighing platform, remove the load plate if necessary.
2. For weighing platforms of type KC, attach the cable to the base frame with a cable tie in such a way that it does not contact the moving lever system.
3. For K...x weighing platforms, pull off the tear-away screw at the terminal box of the weighing platform after connection of the weighing platform to the weighing terminal for safety purposes.
4. Replace load plate if necessary.

## 4.2 Installing additional scale interface or Active CL/IDNet module

Up to two additional scale interfaces (IDNet or analog) or Active CL/IDNet modules can be installed in the ID7sx weighing terminal if not already installed at the factory. The ID7sx, for example, can be connected to another ID7sx as a second display with the Active CL/IDNet-ID7sx module in the hazardous area.

### 4.2.1 Installing IDNet interface or Active CL/IDNet module

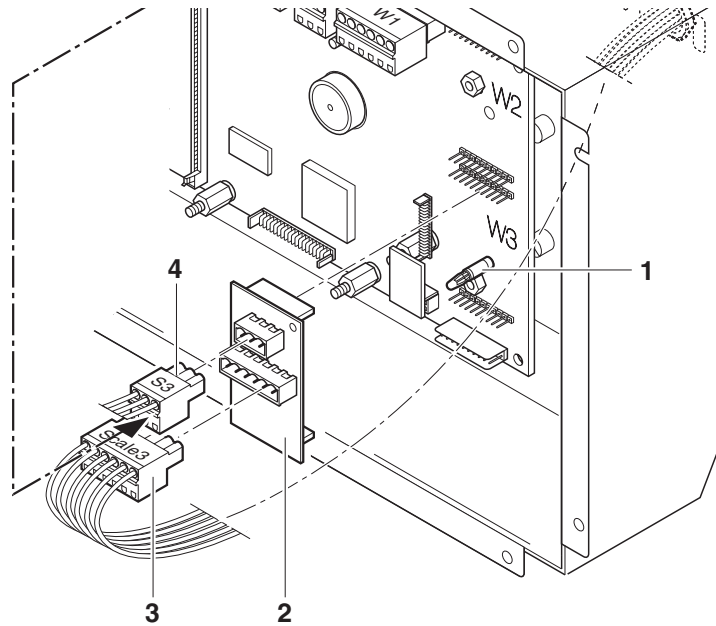

1. Open housing cover of ID7sx and unplug keyboard, display and backlighting cables.
2. Mount spacer (1) at W2 or W3.
3. Attach module Scale-ID7sx (2) to connector W2 or W3. Ensure that the locking tip of the spacer engages here.
4. Remove blind plug from desired scale connection.
5. Insert and mount weighing platform cable. Ensure the correct position of the outer seal when doing so.
6. Label 6-pin plug (3) on module Scale-ID7sx as "Scale 2" or "Scale 3". The stickers are located inside the housing.
7. Connect wires of the weighing platform cable or the interface cable from the master terminal at the 6-pin plug W or W\_A in accordance with terminal diagram 22006478.
8. Lay cable in the cable holder on the inside of the housing.
9. Unplug 3-pin plug (4) "S2" or "S3" from the ID7sx mainboard and insert it into connector S or S\_A on module Scale-ID7sx.
10. Reattach keyboard, display and backlighting cables to the mainboard.
11. Close housing cover of ID7sx again. Ensure correct position of housing seal when doing so.



#### 4.2.2 Installing analog interface

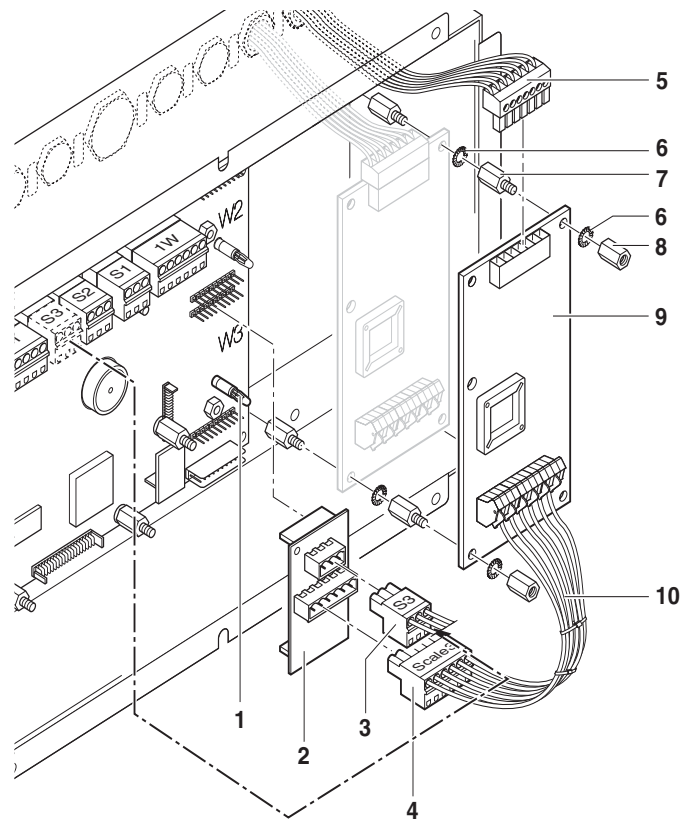

1. Open housing cover of ID7sx and unplug keyboard, display and backlighting cables.
2. Mount spacer (1) at W2 or W3.
3. Attach module Scale-ID7sx (2) to connector W2 or W3. Ensure that the locking tip of the spacer engages here.
4. Unplug 3-pin plug (3) "S2" or "S3" from the ID7sx mainboard and insert it into connector S on module Scale-ID7sx.
5. Label 6-pin plug (4) on module Scale-ID7sx as "Scale 2" or "Scale 3". The stickers are located inside the housing.
6. If only **one Point Ex PCB** (9) is installed:
  - Mount 2 spacer pins (7) at the housing floor.
  - Attach Point Ex PCB and secure with lock washer (6) and nut (8).
7. If **two Point Ex PCBs** (9) are installed:
  - Remove nut (8).
  - Attach first Point Ex PCB and secure with lock washer (6) and spacer pin (7).
  - Attach second Point Ex PCB and secure with lock washer (6) and nut (8).
8. Remove blind plug from desired scale connection.
9. Insert and mount weighing platform cable. Ensure the correct position of the outer seal when doing so.
10. Connect wires of weighing platform cable to plug ST1 (5) of the Point Ex PCB (9) in accordance with terminal diagram 22006478.

11. Lay cable in the cable holder on the inside of the housing.
12. Connect 6-lead connection cable (10) between the 6-pin plug of the Scale-ID7sx module and the ST2 plug at the Point Ex PCB.
13. Reattach keyboard, display and backlighting cables to the mainboard.
14. Close housing cover of ID7sx again. Ensure correct position of housing seal when doing so.

### 4.3 Installing memory module

A Memory-ID7sx memory module can be installed in the ID7sx weighing terminal if not already installed at the factory.

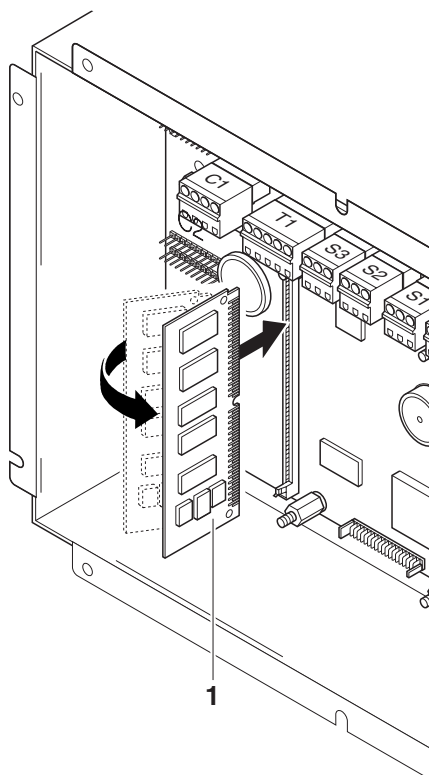

1. Open housing cover of ID7sx and unplug keyboard, display and backlighting cables.
2. Insert the module Memory-ID7sx (1) angled to the left into the SIMM slot and then tilt it to the right until it is perpendicular with the mainboard and the clips engage.
3. Reattach keyboard, display and backlighting cables to the mainboard.
4. Close housing cover of ID7sx again. Ensure correct position of housing seal when doing so.

## 4.4 Installing additional data interface

Up to two additional data interfaces (CL20mA-ID7sx or RS232-ID7sx) can be installed in the ID7sx weighing terminal if not already installed at the factory.

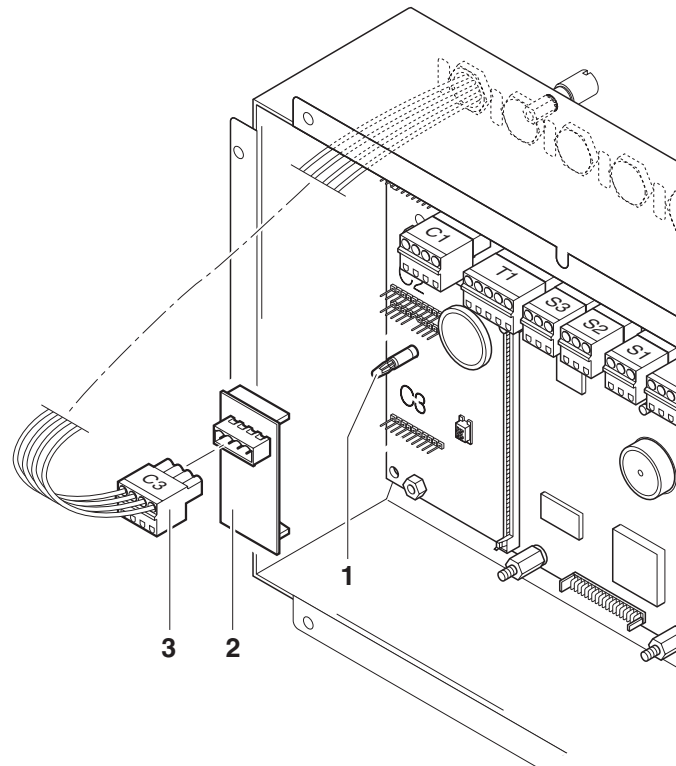

1. Open housing cover of ID7sx and unplug keyboard, display and backlighting cables.
2. Mount spacer (1) at C2 or C3.
3. Mount module CL20mA-ID7sx or RS232-ID7sx (2) to connector C2 or C3. Ensure that the locking tip of the spacer engages here.
4. Remove blind plug from desired interface connection.
5. Insert and mount interface cable. Ensure the correct position of the outer seal when doing so.
6. Label 4-pin plug on module CL20mA-ID7sx or RS232-ID7sx (3) as "C2" or "C3". The stickers are located inside the housing.
7. Connect wires of the interface cable to the 4-pin plug in accordance with terminal diagram 22006478.
8. Lay cable in the cable holder on the inside of the housing.
9. Reattach keyboard, display and backlighting cables to the mainboard.
10. Close housing cover of ID7sx again. Ensure correct position of housing seal when doing so.

## 4.5 Installing digital inputs/outputs

Digital inputs/outputs 8 I/O-ID7sx can be installed in the ID7sx weighing terminal if not already installed at the factory.

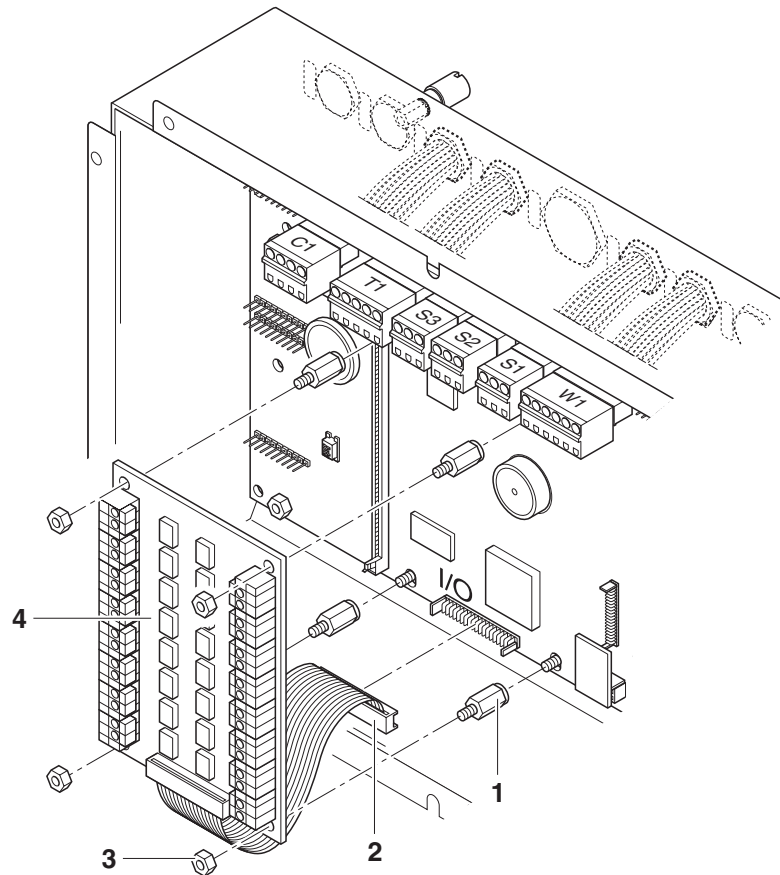

1. Open housing cover of ID7sx and unplug keyboard, display and backlighting cables.
2. Remove the 4 nuts (3) from the mainboard and place 4 spacer pins (1) in their places.
3. Mount the module 8 I/O-ID7sx (4) to the ID7sx mainboard with 4 nuts.
4. Insert ribbon cable (2) into connector I/O on the ID7sx mainboard.
5. Remove blind plug from the back of the housing.
6. Insert and mount interface cable. Ensure the correct position of the outer seal when doing so.
7. Connect wires of the interface cable to module 8 I/O-ID7sx.
8. Lay cable in the cable holders on the inside of the housing.
9. Reattach keyboard, display and backlighting cables to the mainboard.
10. Close housing cover of ID7sx again. Ensure correct position of housing seal when doing so.

## 4.6 Connecting barcode scanner

A barcode scanner, e.g. ELB SK200 (SC20-MTA1), can be connected to the ID7sx weighing terminal via an intrinsically safe RS232 data interface.

The barcode kit for ID7sx consists of the following components:

- Barcode scanner ELB SK200 (SC20-MTA1)
- RS232-ID7sx module
- Viper-Ex slotcard (SW)
- Screw gland

### Mounting

1. Install Viper-Ex (SW) slotcard in the PSU. See PSU installation instructions.
2. Install RS232-ID7sx module in the ID7sx weighing terminal as COM2 or COM3. See Section 4.4.
3. Pull in the barcode scanner cable and mount it with the screw gland.
4. Connect wires of the barcode scanner cable at plug C2 or C3 in accordance with terminal diagram 22006478.

### Caution

The yellow wire insulated with a heat-shrink sleeve may not be connected in the hazardous area!

### Note

- The yellow wire of the barcode scanner cable is insulated with a 1.5 cm heat-shrink sleeve at the factory.
- The green, brown and white wire of the barcode scanner cable is stripped 3 cm at the factory and provided with wire-end ferrules.

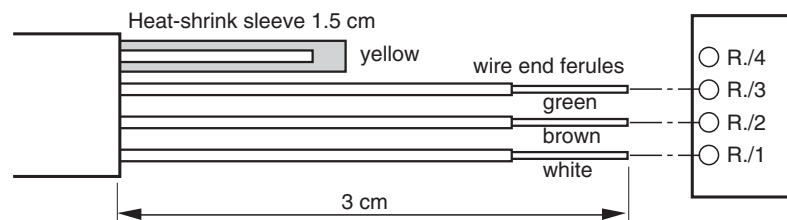

## 4.7 Attaching Profibus-DP module

The ID7sx can be connected to a Profibus network with the Profibus-DP module. The Profibus-DP module is a top-hat rail module for installation in the control cabinet. It requires an external power supply of 24 V DC +/- 20%, 100 mA.

### Condition

A slotcard interface with the RS232-PSU module must be installed and connected up in the PSU for a data interface CL20mA-ID7sx of the ID7sx. See Section 4.4 or the PSU installation instructions.

1. Insert the Profibus-DP module at the relevant interface connection of the PSU.
2. Connect the Profibus-DP module to the 24 V power supply.
3. Integrate the Profibus-DP module into the Profibus network.
4. In master mode of the ID7sx, select the PROFIBUS DP operating mode for the relevant interface and set parameters. See ID7sx weighing terminal operating instructions.
5. De-energise the Profibus-DP module after setting all parameters.
6. Connect the Profibus-DP module to the power supply again. The parameter settings made are now active and the ID7sx is integrated into the Profibus-DP network.

# 5 Dimensional drawings

## 5.1 Desk unit

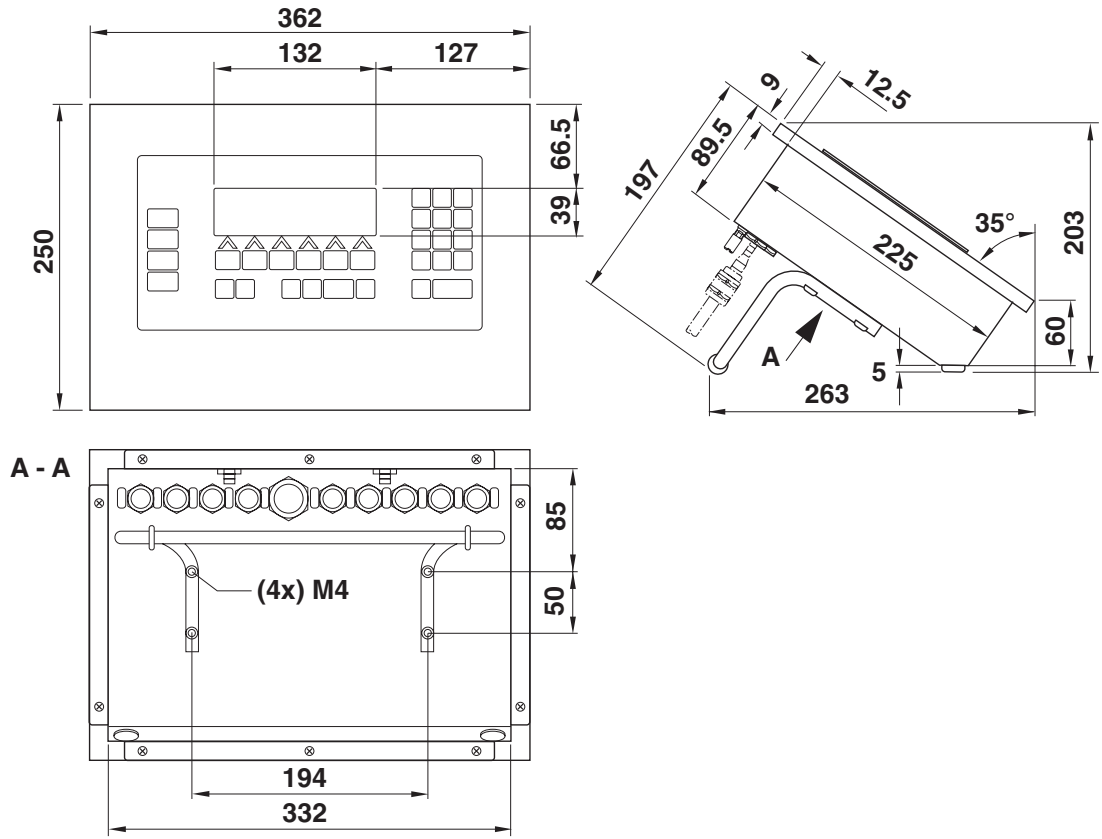

Dim. in mm

### 5.2 Panel unit

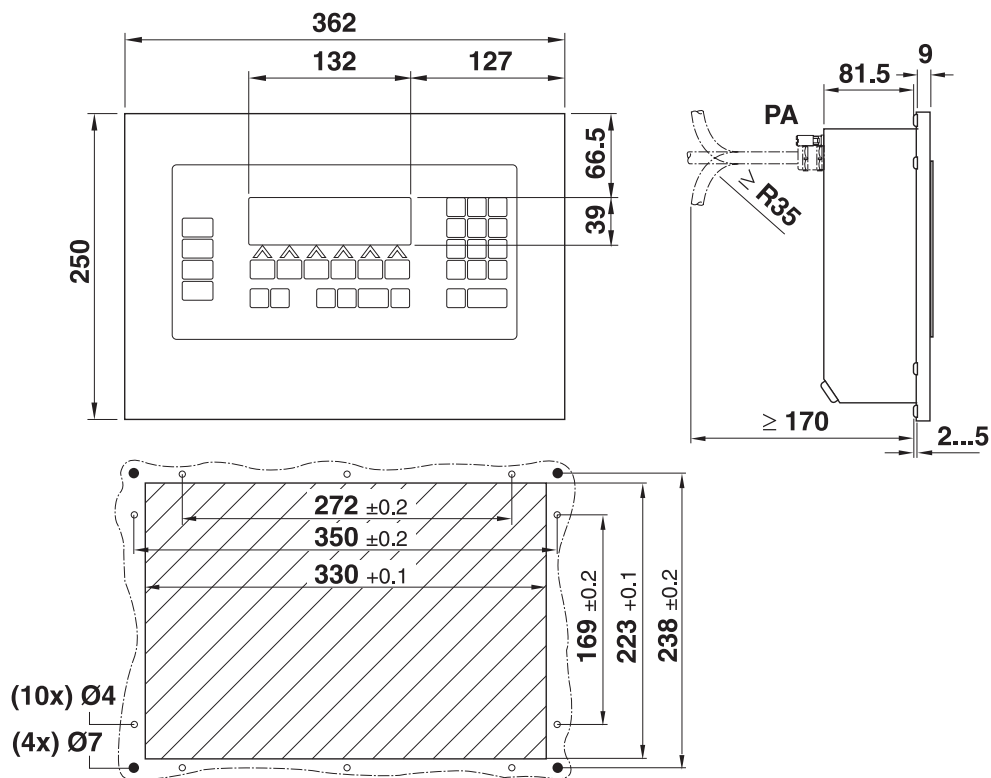

Dim. in mm

### 5.3 Wall unit

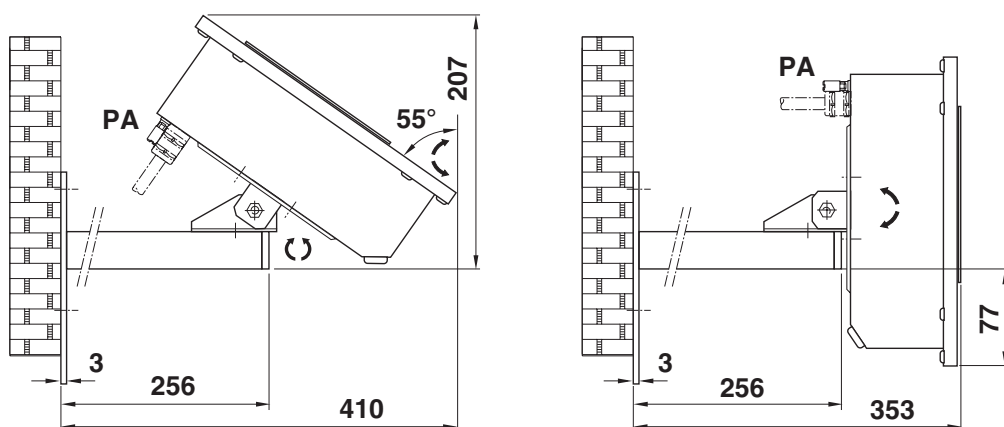

Dim. in mm



### Drilling template

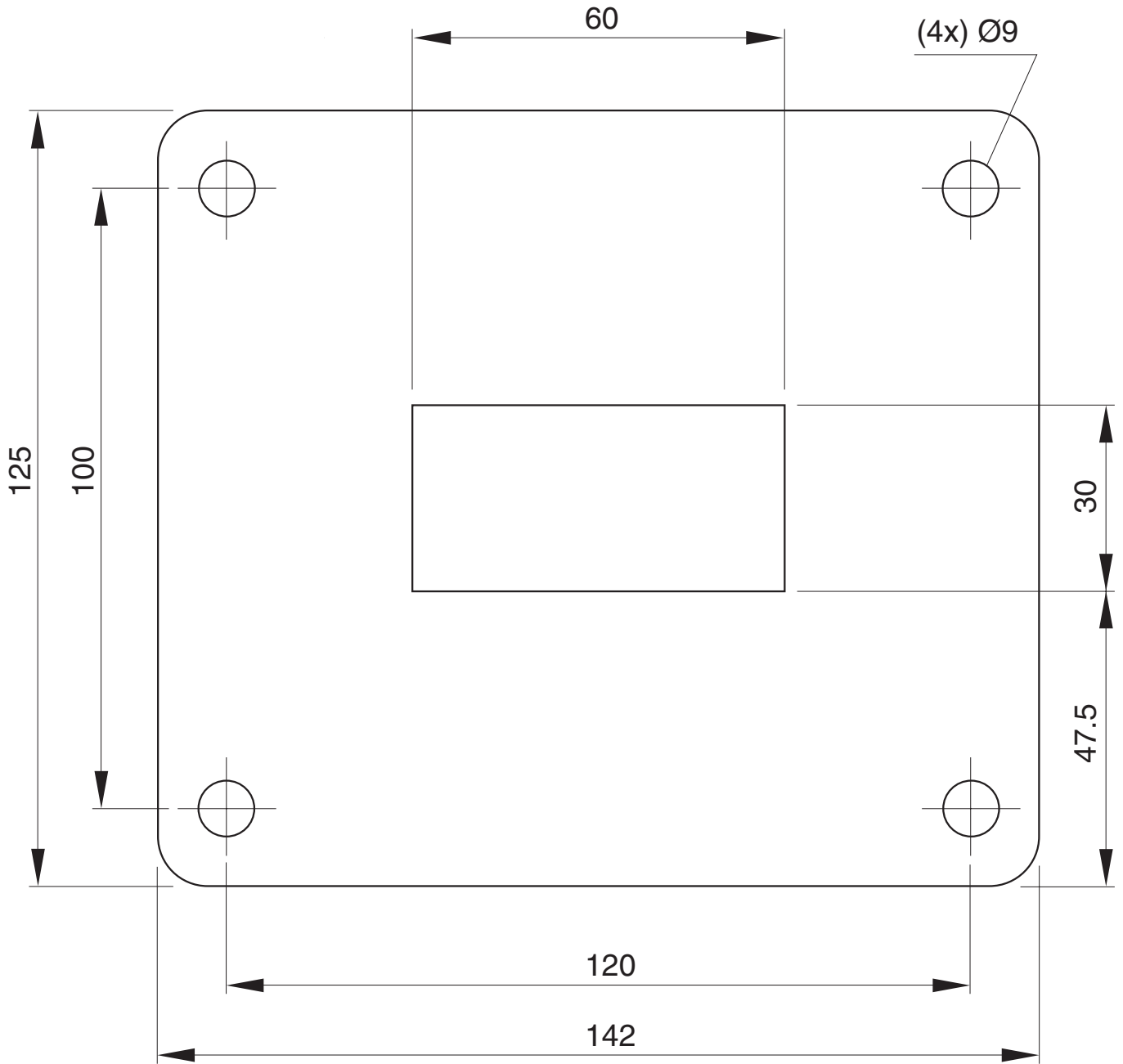

Dim. in mm

**nefton**  
Ζύγιση  
Σήμανση  
Συμμόρφωση

**Νεύτων Τεχνολογίες ΑΒΕΕ**

Γέρακα 113, Τ.Θ. 67934

15344 Γέρακας

Τηλ: 210 6654544

Fax: 210 6654545

marketing@nefton.gr

www.nefton.gr



**22008316B**

Subject to technical changes © Mettler-Toledo (Albstadt) GmbH 04/09 Printed in Germany 22008316B

**Mettler-Toledo (Albstadt) GmbH**

D-72458 Albstadt

Tel. ++49-7431-14 0, Fax ++49-7431-14 232

Internet: <http://www.mt.com>