

Pallet Truck Scale

BTA425 / BTA445

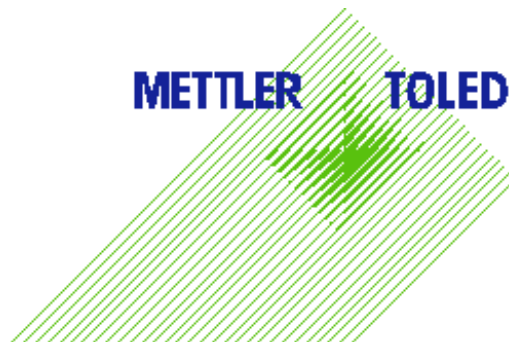

METTLER TOLEDO



Specification sheet BTA425 and BTA445

Lifting capacity	2000 kg
Weighing capacity	1500 or 2000 kg
Electronics	BTA425 supplied with IND425 BTA445 supplied with IND445
Graduations:	
Version 1500 kg	Multi-interval: 0-600 kg in 0.2 kg graduation 600-1500 kg in 0.5 kg graduation
Version 2000 kg	Multi-interval: 0-1000 kg in 0.5 kg graduation 1000-2000 kg in 1 kg graduation
Maximum error	0.1 % of the applied load (non legal for trade) Legal for trade conform EU-Specifications (incl. level switch for switching off display at inclinations over 2 degrees)
Power supply	Exchangeable battery module 12 Vdc / 1,2 Ah
Battery Autonomy	8 hours
Battery charging level	Indication in display (charger 230 Vac / 12 Vdc included)
Rotating indicator	360 degrees with stop, for readout from different angles
Wheels	Rubber steering wheels Polyurethane loading wheels (tandem)
Color	RAL 5003

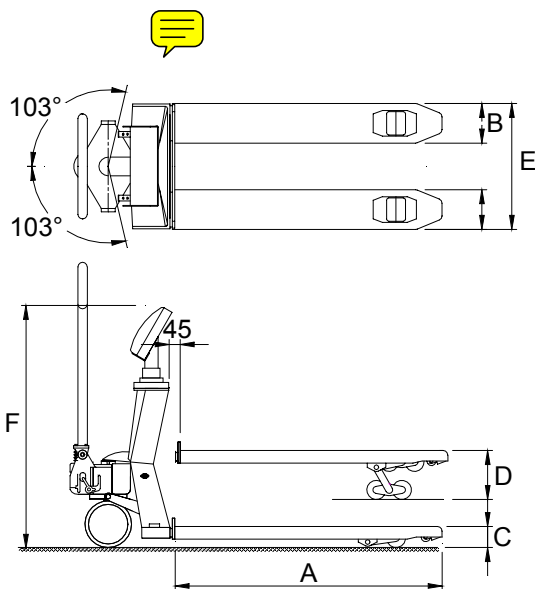

DIMENSIONS

A = Fork length	1150 mm
B = Fork width	180 mm
C = Fork height	85 mm (+/- 2 mm)
D = Lifting height	205 mm
E = Width over the forks	555 mm (+/- 5 mm)
F = Top indicator height	910 mm

OPTIONS

Version legal for trade
Integrated printer for printing out weights
Extra exchangeable battery module
Stainless steel fork shoes
Different loading or steering wheels
Different dimensions
Footbrake

METTLER TOLEDO

nefton
Ζύγιση
Σήμανση
Συμμόρφωση

Νείτων Τεχνολογίες ΑΒΕΕ
Γέρακα 113, Τ.Θ. 67934
15344 Γέρακας
Τηλ: 210 6654544
Fax: 210 6654545
marketing@nefton.gr
www.nefton.gr

Rev.29.06.05.2