

9040 Contrast

small character inkjet printers ■ ■ ■



Our technology ■ ■ ■

9000 Series printers offer the best balance between performance and flexibility in their segment for an easy integration in all manufacturing environments. Their state-of-the-art design requires minimal attention and provides high quality coding.

The continuous inkjet technology prints logos, alphanumeric text and 1D and 2D barcodes. The 9040 Contrast is the best solution for marking in automotive, aerospace, cable and extrusion industries.

Your benefits ■ ■ ■

Simplicity – Ergonomic design with an intuitive user interface featuring shortcuts and direct access to consumables. Easy and quick installation of the cabinet on the floor for user-friendly operations.

Performance – High speed marking for cable and extrusion industries. Standard ethernet connectivity.

Quality – Automatic ink-pressure adjustment (Jet Speed Control) guaranteeing print quality.

Uptime – Easy change of the consumables without stopping marking operations.

Versatility – Wide choice of inks and colours, including pigmented inks for high contrast printing on dark surfaces. Mono- or twin-jet. 2 printing resolutions (71 and 115 dpi).



markem·imaje

the team to trust ■ ■ ■

9040 Contrast specifications ■ ■ ■

Print features ■ ■ ■

- Mono or bi-jet printhead
- G head (printing resolution: 71 dpi) - M head (printing resolution: 115 dpi)
- Up to 8 lines of text
- Print speed: up to 5.5 m/s
- Font sizes from 5 dots to two 24-dot lines
- Character height from 1.2 mm to 18.2 mm
- One and two-dimensional barcodes (Datamatrix)
- Wide selection of characters (Latin, Arabic, Cyrillic, Greek, Japanese, Chinese, Hebrew, Korean...)

Available configurations ■ ■ ■

	9040 Contrast
1.1 G	•
1.2 G	•
1.1 M	•
1.2 M	•

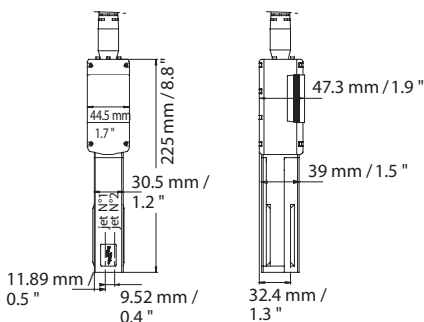

Operations ■ ■ ■

- Message library (up to 2000 messages)
- User interface available in 29 languages
- Large WYSIWYG backlit display
- Creation of logos directly on the user interface
- PCMCIA, Compact Flash and SD cards capable
- USB Port
- Jet Speed Control for optimum print quality
- Automatic font selection; print speed and printhead to substrate distance dependent
- Wide range of inks: pigmented, quick-drying, alcohol-based...
- 2 tanks (1 liter each)
- Quick connect interface panel for accessories (photocell, encoder, alarm)
- RS-232 connectivity and I/O slot for remote access
- Ethernet connectivity

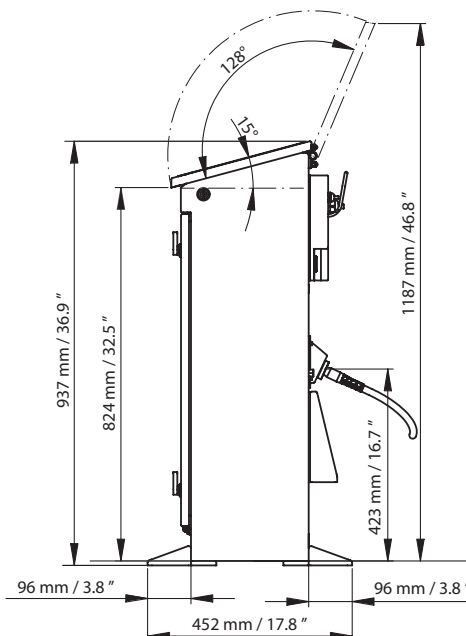

Other characteristics ■ ■ ■

- Weight: 40 kg
- 3-meter flexible umbilical
- Stainless steel cabinet
- Dust/humidity protection rating: IP54
- Operating temperature range: 0° to 50° C
- Humidity: 10% to 90% non-condensing
- Electrical power supply: 100-120 V or 200-240 V with automatic switching; frequency 50/60 Hz; power 120 VA

Accessories ■ ■ ■

- Printhead stand (aluminum or stainless steel)
- Various printhead brackets
- Stainless steel printhead cover
- Photocell
- Encoder
- Alarm beacon (24 V)

Options ■ ■ ■

- RS-422 connectivity
- Parallel interface
- Printhead pressurization kit
- 90° bent umbilical
- 90° bent printhead

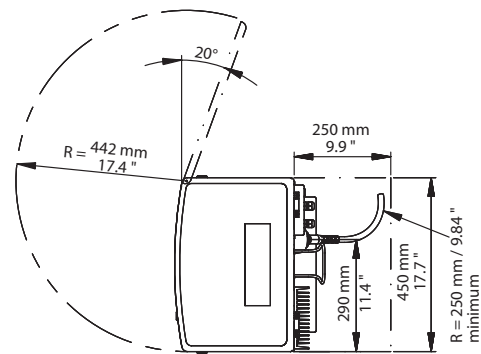

To learn more visit, www.markem-imaje.com



We reserve the right to amend the design and/or specifications of our products without notice.

9, rue Gaspard Monge
B.P. 110
26501 Bourg-lès-Valence Cedex - France
Tel.: +33 (0) 4 75 75 55 00
Fax: +33 (0) 4 75 82 98 10

150 Congress Street
Keene, NH 03431
United States of America
Tel.: +1 800-258-5356
Fax: +1 603-357-1835



A DOVER Company

Photos: Ginko
Printed in France - A37154 - 03/08 - A1